

SPECIFICATIONS

MEASUREMENTS

Lamps	Metal halide 4 x 1,000 W
Generator	Brushless 60 Hz, 8.0 kW
Engine	Kubota® diesel 13.6 hp
Receptacles	One GFI duplex 20 A / 120 V One T/L 30 A / 240 V
Fuel capacity	30 gal (114 L)
Wheel size	15 in (38 cm)
Axle rating	3,500 lbs (1,558 kg)
Tongue weight travel position	167 lbs (76 kg)
Total weight no fuel	2,239 lbs (1,016 kg)

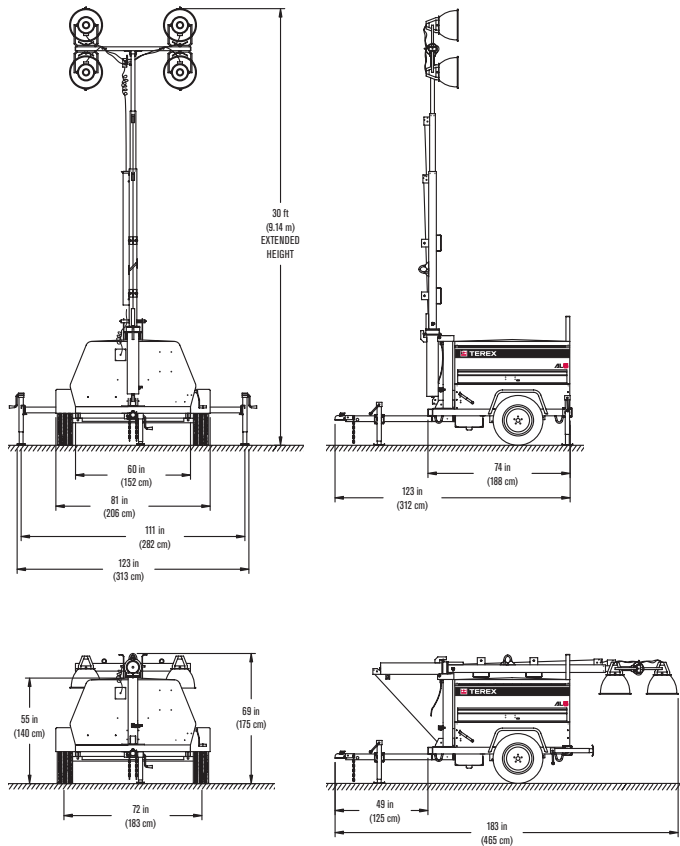

Notice: Metal halide lamp bulbs contain mercury (Hg). Dispose of lamp bulbs according to local, state and federal laws.

FEATURES

- 4 X 1000 W metal halide lights with Kubota engine and 8kW generator.
- Option for up to 20kW generator with plenty of extra power to run all of your tools.
- Durable 30 ft (9.18 m) fully galvanized mast with single self-braking winch design, 359 degree rotation, and retractable mast cable gives excellent illumination at long distances.
- Standard engine protection includes high water temperature and low oil auto shutdowns.
- Quick disconnect lights and ballasts allow for easy troubleshooting, service, and repair. Internal storage system for light fixtures provides safekeeping and protection during transport.
- Standard DOT approved run, stop and turn lights
- Heavy duty mast, chassis, and 3,500 lbs (1,558 kg) rated axle to handle rough road towing.
- Highway safety chains with snap hook

AL™5 LIGHT TOWER



CHASSIS OPTIONS

- 30 gal fuel tank w/ spill containment
- 60 gal fuel tank
- 60 gal fuel tank w/ spill containment
- Export racking and preparation
- Extra GFI duplex receptacle with breaker
- Hitch, 2 1/2 in. ring
- Hitch, 2 5/16 in. ball
- Hitch, combination ring and ball
- Rubber door hold-down latches
- Spare tire and wheel
- Tough coat paint surface: cabinet and trailer front
- Trailer brakes, electric
- Trailer brakes, Hydraulic surge: must specify ring or ball hitch

ENGINE OPTIONS

- 12 kW, 60 Hz generator with 16.3 hp (12.1 kW) Kubota® diesel
- 20 kW, 60 Hz generator with 29.2 hp (21.7 kW) Isuzu turbo diesel, includes external receptacle package, and 2 ea. 20A/120V GFI & 3 ea. 30A/240V T/L, 700 CCA battery
- 15.5kW, 50 Hz generator
- Automatic air shutdown
- Fuel/water separator filter
- Fuel/water separator with fuel line heater

TOWER OPTIONS

- 6 metal halide lights
- Electric winch

COLD WEATHER OPTIONS

- Cold weather package: 700 CCA battery, battery blanket heater, engine block heater, low temp coolant (-40°F)
- Deluxe cold weather package: 1000 CCA battery, battery blanket heater, engine block heater, low temp coolant (-40°F)



WORKS FOR YOU.™

SPECIFICATIONS

AL™5 LIGHT TOWER VERTICAL MAST

MEASUREMENTS

Lamps	Metal halide 4 x 1,000 W
Generator	Brushless 60 Hz, 8.0 kW
Engine	Kubota® diesel 13.6 hp
Receptacles	One GFI duplex 20 A / 120 V One T/L 30 A / 240 V
Fuel capacity	30 gal (114 L)
Wheel size	15 in (38 cm)
Axle rating	3,500 lbs (1,558 kg)
Tongue weight travel position	310 lbs (141 kg)
Total weight no fuel	2,498 lbs (1,133 kg)

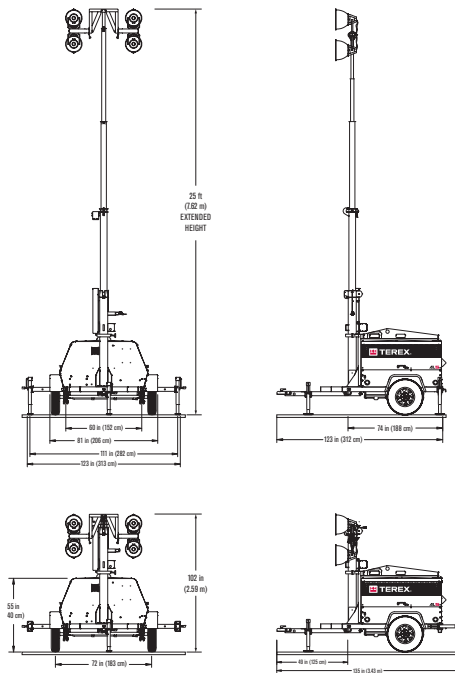

Notice: Metal halide lamp bulbs contain mercury (Hg). Dispose of lamp bulbs according to local, state and federal laws.

FEATURES

4 X 1000 W metal halide round lights with Kubota engine and 8kW generator.

Option for up to 20kW generator with plenty of extra power to run all of your tools.

Electrically powered winch for quick setup.

359 degree rotation raised or stowed.

Durable 25 ft (7.6 m) fully galvanized mast with single self-braking winch design, 359 degree rotation, and retractable mast cable gives excellent illumination at long distances.

Standard engine protection includes high water temperature and low oil auto shutdowns.

Quick disconnect lights and ballasts allow for easy troubleshooting, service, and repair. Internal storage system for light fixtures provides safekeeping and protection during transport.

Standard DOT approved run, stop and turn lights

Heavy duty mast, chassis, and 3,500 lbs (1,558 kg) rated axle to handle rough road towing.

Highway safety chains with snap hook

CHASSIS OPTIONS

30 gal fuel tank w/ spill containment

60 gal fuel tank

60 gal fuel tank w/ spill containment

Export racking and preparation

Extra GFI duplex receptacle with breaker

Hitch, 2 1/2 in. ring

Hitch, 2 5/16 in. ball

Hitch, combination ring and ball

Rubber door hold-down latches

Spare tire and wheel

Tough coat paint surface: cabinet and trailer front

Trailer brakes, electric

Trailer brakes, Hydraulic surge: must specify ring or ball hitch



ENGINE OPTIONS

12 kW, 60 Hz generator with 16.3 hp (12.1 kW) Kubota® diesel

20 kW, 60 Hz generator with 29.2 hp (21.7 kW) Isuzu turbo diesel, includes external receptacle package, and 2 ea. 20A/120V GFI & 3 ea. 30A/240V T/L, 700 CCA battery

15.5kW, 50 Hz generator

Automatic air shutdown

Fuel/water separator filter

Fuel/water separator with fuel line heater

COLD WEATHER OPTIONS

Cold weather package: 700 CCA battery, battery blanket heater, engine block heater, low temp coolant (-40°F)

Deluxe cold weather package: 1000 CCA battery, battery blanket heater, engine block heater, low temp coolant (-40°F)

TOWER OPTIONS

4 horizontally mounted lights, cast aluminum square housing

www.genielift.com

Effective Date: January, 2016. Product specifications and prices are subject to change without notice or obligation. The photographs and/or drawings in this document are for illustrative purposes only. Refer to the appropriate Operator's Manual for instructions on the proper use of this equipment. Failure to follow the appropriate Operator's Manual when using our equipment or to otherwise act irresponsibly may result in serious injury or death. The only warranty applicable to our equipment is the standard written warranty applicable to the particular product and sale and we make no other warranty, express or implied. Products and services listed may be trademarks, service marks or trade names of Terex Corporation and/or their subsidiaries in the USA and many other countries. Terex, Genie and Works For You are trademarks owned or licensed by Terex Corporation or its subsidiaries. All other trademarks are property of their respective owners. © 2016 Terex Aerial Work Platforms. AL5 0210H Part #109046

Genie United States
6464 185th Ave. NE
Redmond, WA 98052
Telephone +1 (425) 881-1800
Toll Free in USA/Canada +1 (800)-536-1800
Fax +1 (425) 883-3475

Distributed By:



WORKS FOR YOU.™