

# SPECIFICATIONS

## MEASUREMENTS

Lamps	Metal halide 4 x 1,000 W
Generator	Brushless 60 Hz, 6.0 kW
Engine	Kubota® diesel 13.6 hp
Receptacles	One GFI duplex 20 A / 120 V One T/L 30 A / 240 V
Fuel capacity	30 gal (114 L)
Wheel size	15 in (38 cm)
Axle rating	3,500 lbs (1,558 kg)
Tongue weight travel position	147 lbs (67 kg)
Total weight no fuel	1,950 lbs (885 kg)

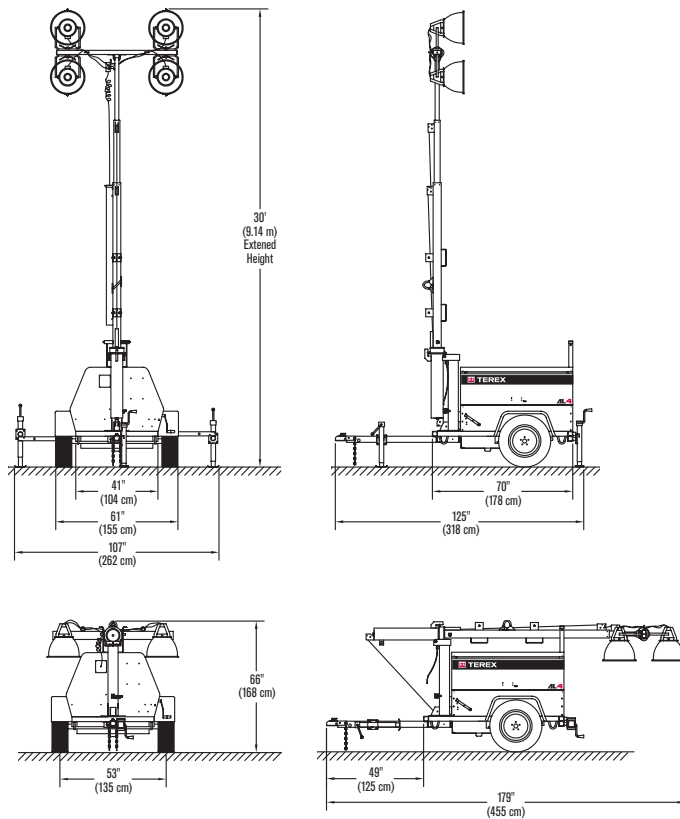

Notice: Metal halide lamp bulbs contain mercury (Hg). Dispose of lamp bulbs according to local, state and federal laws.

## FEATURES

4 X 1000 W metal halide lights with Kubota engine and 6kW generator which provides quiet 71 dBA at 23 feet and fuel efficient 60 hour run time.

Durable 30' fully galvanized mast with single self-braking winch design, 359 degree rotation, and retractable mast cable gives excellent illumination at long distances.

Standard engine protection includes high water temperature and low oil auto shutdowns.

Quick disconnect lights and ballasts allow for easy troubleshooting, service, and repair.

Standard DOT approved run, stop and turn lights

Heavy duty mast, chassis, and 3,500 lbs rated axle to handle rough road towing.

Highway safety chains with snap hook

Telematics ready

# AL™4 LIGHT TOWER



## CHASSIS OPTIONS

30 gal fuel tank w/ spill containment

50 gal fuel tank

Dome light with switch, 12V

Export racking and preparation

Hitch, 2 1/2 in. ring

Hitch, 2 5/16 in. ball

Hitch, combination ring and ball

Spare tire and wheel

Tough coat paint surface: cabinet and trailer front

Trailer brakes, electric

Trailer brakes, Hydraulic surge: must specify ring or ball hitch

## ENGINE OPTIONS

6 kW, 60 Hz, generator with 15.3 hp Perkins® diesel

7 kW, 50 Hz, generator with 13.6 hp Kubota® diesel

8 kW, 60 Hz, generator with 13.6 hp Kubota® diesel

Automatic air shutdown

Fuel/water separator filter

Fuel/water separator with fuel line heater

## TOWER OPTIONS

4 horizontally mounted lights, cast aluminum square housing

Electric winch

## COLD WEATHER OPTIONS

Cold weather package including: 700 CCA battery, battery heater blanket, engine block heater and low temperature coolant (-40F)



WORKS FOR YOU.™

[www.genielift.com](http://www.genielift.com)

Effective Date: January, 2016. Product specifications and prices are subject to change without notice or obligation. The photographs and/or drawings in this document are for illustrative purposes only. Refer to the appropriate Operator's Manual for instructions on the proper use of this equipment. Failure to follow the appropriate Operator's Manual when using our equipment or to otherwise act irresponsibly may result in serious injury or death. The only warranty applicable to our equipment is the standard written warranty applicable to the particular product and sale and we make no other warranty, express or implied. Products and services listed may be trademarks, service marks or trade names of Terex Corporation and/or their subsidiaries in the USA and many other countries. Terex, Genie and Works For You are trademarks owned or licensed by Terex Corporation or its subsidiaries. All other trademarks are property of their respective owners. © 2016 Terex Aerial Work Platforms. AL4 0210G Part #109045

Genie United States  
6464 185th Ave. NE  
Redmond, WA 98052  
Telephone +1 (425) 881-1800  
Toll Free in USA/Canada +1 (800)-536-1800  
Fax +1 (425) 883-3475

Distributed By:



**WORKS FOR YOU.™**