



Paver Special

PS Series Trailers

Rear Loading Lowbeds

- Fast and easy hydraulically operated ramps
- Carry roller, paver and broom in one trip
- One man operation
- Low rear ramp climb angle



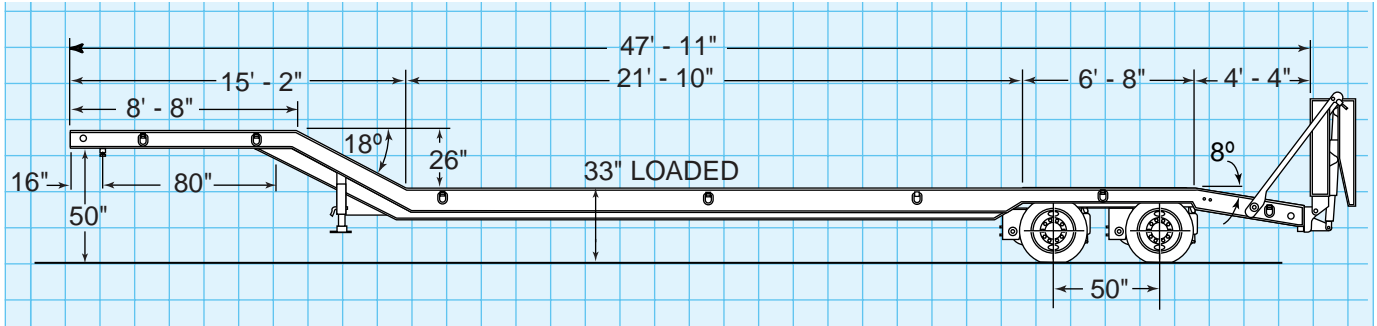

GENERAL SPECIFICATIONS R35TL-PS-T1

50,000# Capacity Payload (R25TL-PS-T1)
 70,000# Capacity Payload (R35TL-PS-T1)
 48'-0" Overall Length
 Fixed (Rigid) Gooseneck
 Full Width Gooseneck
 King Pin Setting - 16"
 Swing Clearance - 80"
 3:1 Gooseneck Slope (18°)
 Level Platform (Deck)
 Fifth Wheel Height - 50" Loaded
 Telescopic Drop Legs
 Concentrated Load in 16'-0"
 Main Frame - Two (2) Beam Design (Cambered)
 100,000 P.S.I. Steel Mainbeams
 One (1) Piece Crossmembers on 24" Centers
 Deck Height - 33" Loaded
 Deck Width - 8'-6" (102")
 Decking - 1 1/2" Apitong (Full Width)
 Decking Securement - Deck Screws
 Hydraulic Bi-fold Ramps (8' X 36"...12.2°)

12 Volt Electric-hydraulic Power Package
 Covered Wheel Wells - 1/4" Steel Floor Plate
 4'-4" (52") Sloping Afterdeck/Wood Covered
 Air Ride Suspension
 Manual Air Exhaust
 Tires - 215/75R 17.5 (H) 16 PR Tubeless Radials
 Wheels - 6.75 X 17.5 Steel Disc (White)
 Hubs - Ball Seat (Stud Piloted)
 Brakes - 12 1/4" X 7 1/2" Air
 Spring Brakes – Rear Axle
 Anti-lock Brakes (2S/2M System)
 Automatic Slack Adjusters
 Axles - 22,500# (5/8" Wall) with Oil Bearings
 Lighting - Sealed Beam - Rubber Mounted
 Finish - Shot Blast/Primer/Black Enamel Finish
 Air Lines - Glad Hands
 Electrical - 7 Way Receptacle
 Lash Rings - 14 Total (7 Each Side/Bent Style)
 Mud Flaps
 Red and White Conspicuity Markings

Optional Features

96", 108" and 120" Gooseneck Swing Clearance
 2 Speed Landing Gear
 Tool Box
 Extra Deck Length (in 2' increments)
 12'x36" wide Bi-fold Ramps (8°)
 Multi-leaf Spring Suspension (increases load angles)
 Hubodometer
 25,000# Axles (3/4" wall)
 235/75R17.5(H) Tires
 255/70R22.5(H) Tires (16 1/2" x 7" brakes) –
 raises deck height and increases load angle
 Cast Spoke Wheels
 Additional Lash Rings
 80,000# Capacity Payload (R40TL3-PS-T1)
 100,000# Capacity Payload (R50TL3-PS-T1)
 Red or Yellow Paint



Fast and easy hydraulically operated bi-fold ramps. Shown with optional 12' ramps.

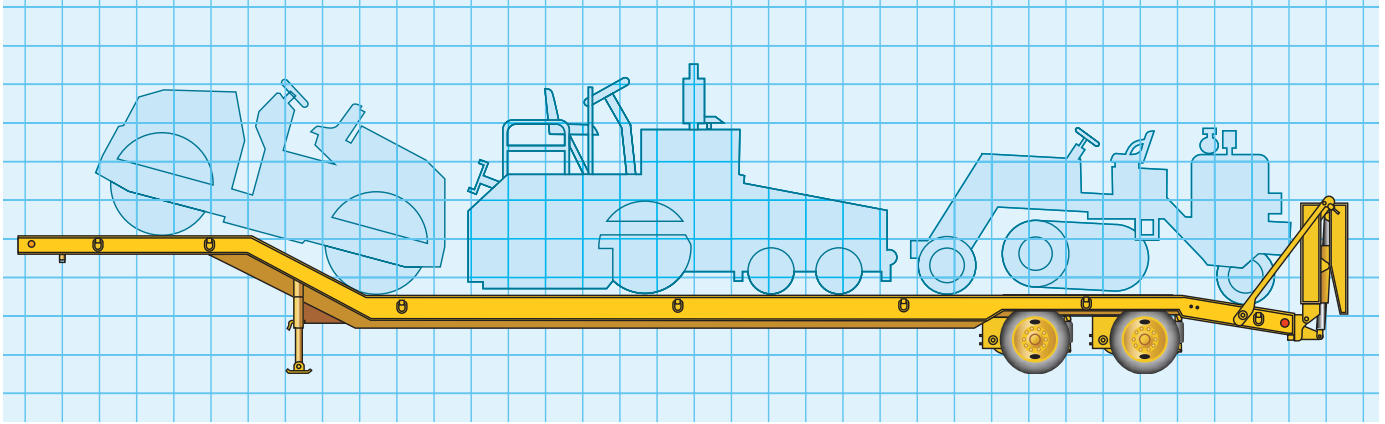

Loading example of typical roller, paver and broom. Because of the variety of paving equipment available, please check the dimensions of your equipment to determine the proper trailer size for you. Certain combinations of equipment could exceed legal size and weight limitations. Verify local requirements prior to ordering. Various combinations of dimensions are available to meet your specific needs.



One man operation with electric/hydraulic bi-fold operated ramps. Shown with optional 12' ramps.



Optional 12' x 36" wide ramps offer an 8° climb angle.



The standard manual exhaust feature on the air suspension enhances the low rear climb angles. Shown with optional 12' ramps.



The full width gooseneck with a 3 to 1 slope accommodates most rollers.

Rear Loading Trailers

Paver Special Load Angles

8' - 0" Ramp (Standard)

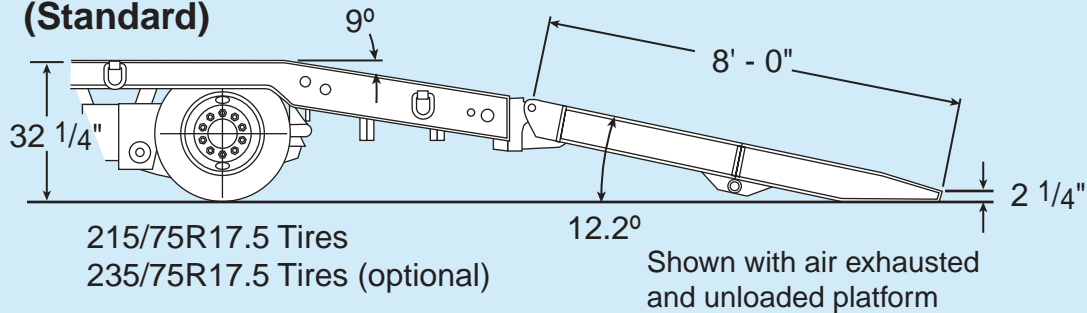

12' - 0" Ramp (Optional)

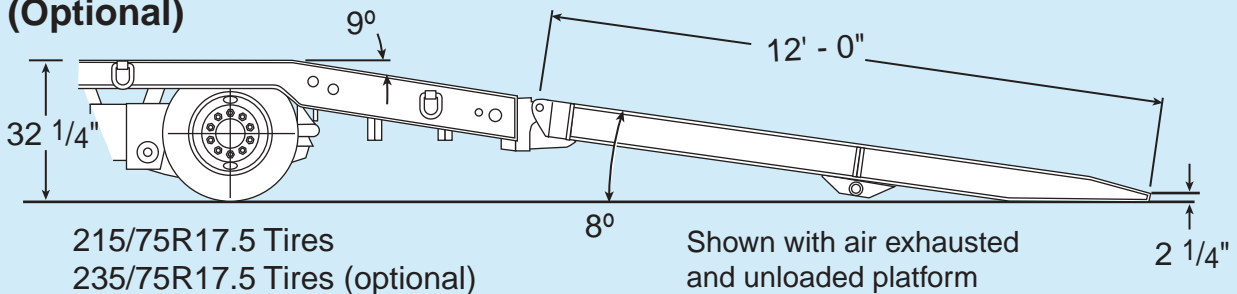

8' - 0" Ramp (Standard)

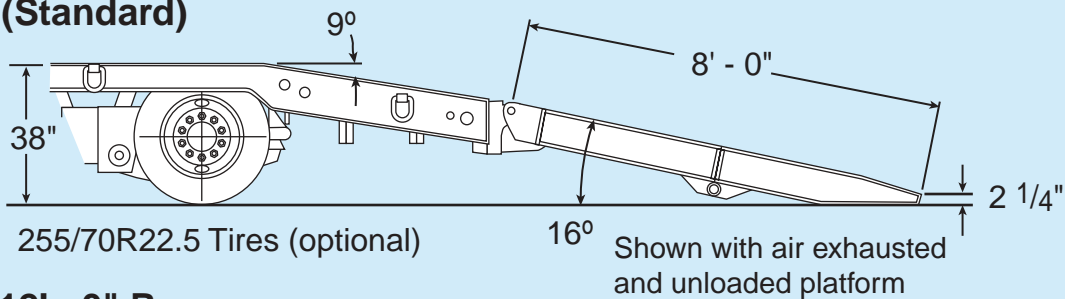

12' - 0" Ramp (Optional)

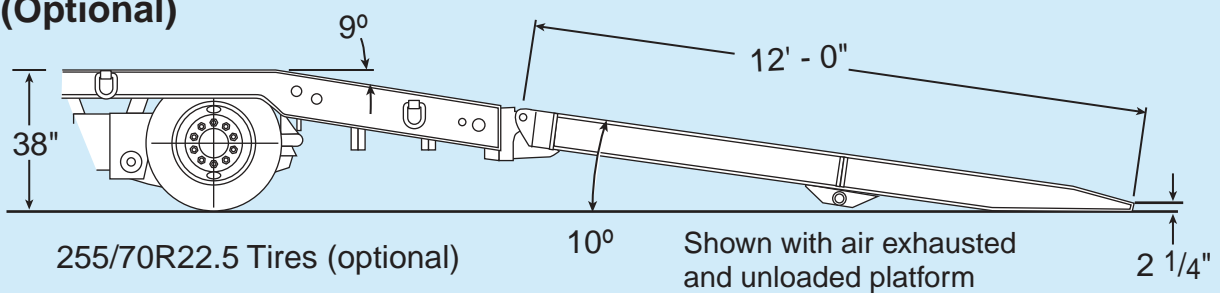

E. D. ETNYRE & CO., whose policy is one of continuous improvement, reserves the right to change specifications without notice. Some items shown in photos and illustrations may be optional equipment.



E. D. ETNYRE & CO.

1333 S. Daysville Road, Oregon, IL 61061
Phone: 815/732-2116 or 800/995-2116
Fax: Sales 815-732-7400
Web Site: www.etnyre.com
E mail: sales@etnyre.com

L-RPS-03 Supersedes L-RPS-99