

# EH5000

## EH5000AC-3

**NOMINAL PAYLOAD:**  
296 tonnes (326 tons)

**OPERATING WEIGHT:**  
500 000 kg (1,102,311 lb.)

**RATED POWER:**  
2 125 kW (2,850 hp)



## WE DIG. WE HAUL. THAT'S ALL.

### HAULER FOCUSED. NO DISTRACTIONS.

At Hitachi, we don't get sidetracked building every kind of mining equipment. Instead, we build trucks and excavators. It's that kind of engineering and manufacturing focus that results in highly reliable trucks that deliver efficient, powerful performance.

The EH5000AC-3 is our largest rigid frame hauler ever. This huge-capacity hauler combines our time-proven truck technology with our newest and most efficient Advanced IGBT AC-Drive system. It's one of the most technologically advanced mining trucks in the world, and it helps raise profits by lowering fuel and maintenance costs. When you put the EH5000AC-3 on the job, it doesn't just get work done, it...

### GETS MORE WORK DONE.

■ **Hitachi AC Technology.** Hitachi has been at the forefront of both Gate Turn Off (GTO) and IGBT propulsion technology for over 30 years. Now, the company has channeled this expertise into Hitachi AC-drive trucks.

**Unlike all other competitors, the entire AC-drive system is designed, built, and supported by the same company — HITACHI**

The new-generation Hitachi IGBT system outperforms previous and competitive systems through its simplicity, improved efficiency, and enhanced dependability. It couples the best GTO features with higher torque, faster acceleration, smoother retardation, and lower operating costs.

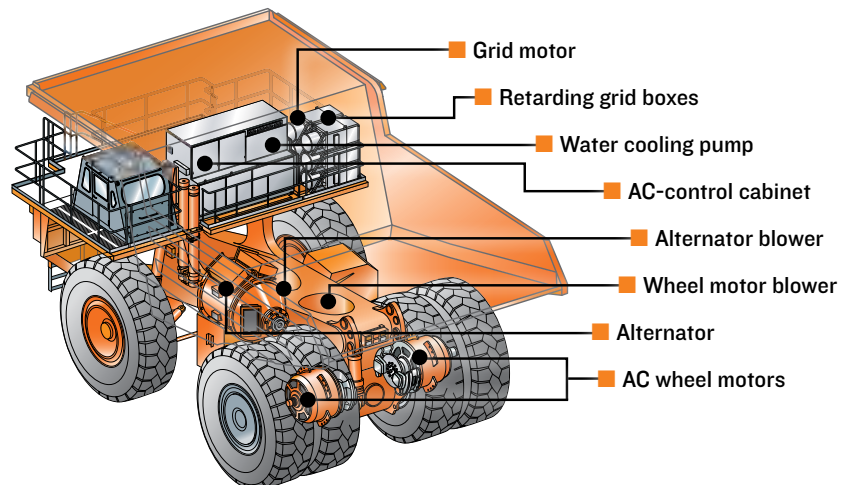

# SPECIALISTS



■ **Economical.**

Our new Advanced AC-Drive System makes the EH5000AC-3 a more valuable asset for your mining operations. It delivers better performance, higher uptime and helps significantly reduce maintenance and fuel costs.

■ **Efficient.**

The EH5000AC-3 is also equipped with a Cummins QSKTT A60-CE diesel engine that generates 2125 kW (2,850 hp) at 1,900 rpms, and meets Tier 2 EPA emission requirements.

■ **Long frame life.**

The frame on the EH5000AC-3 has also been redesigned and improved for longer life. The bolt-on high-arch cross member, combined with new rear axle housing and nose cone designs give the EH5000AC-3 the sturdiest frame of all.

■ **High capacity.**

The EH5000AC-3 gives you the ability to handle the biggest hauling jobs of all. The nominal payload is at a very high level – 296 tonnes (326 US tons).

# INNOVATION

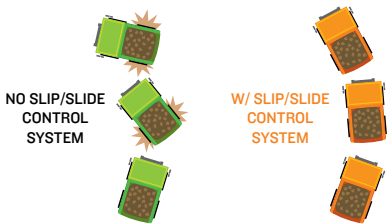

**Slip/slide control system**

The enhanced Slip/Slide Control System is an active traction control and anti-lock brake system in slippery conditions. The enhanced performance of the Slip/Slide Control System comes from the utilization of various new sensors on the front wheels, suspension and steering systems.

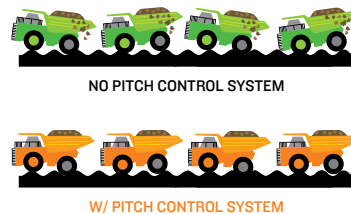

**Pitch control system**

The Pitch control feature of the Advanced AC-Drive System reduces bouncing/rebounding on the truck as it hits bumps or uneven ground on the haul road. As the truck comes to a stop the rebounding or rocking effect due to the change in inertia of the truck is also reduced.

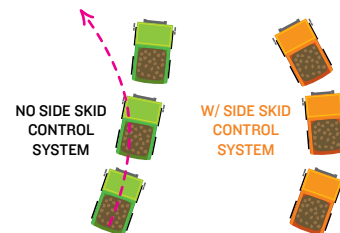

**Side skid control system**

The Advanced AC-Drive System also provides a side skid control feature that helps the operator in slippery road conditions when making turns. By utilizing changes in the wheel motor torque from left-to-right during cornering, it assists the operator in turning the truck and keeping it on the proper track.

# THE MOST ADVANCED AC-DRIVE SYSTEM EVER.

## INNOVATION, NOT IMITATION.

Want the most productive and efficient AC-drive technology in the world? Choose Hitachi. The EH5000AC-3 runs with Hitachi's newest, state-of-the-art Advanced AC-Drive System using Hitachi's own IGBT controller, alternator and wheel motors. Hitachi has been in the electrical drive system business for years – first with GTO, now with IGBT. In fact, the technology has successfully been used on bullet trains, locomotives, monorails and commuter electric cars around the world. The result is an AC-powered truck that outperforms previous and competitive systems through its simplicity, improved efficiency and enhanced dependability.

Another important thing to know is that Hitachi is the only truck manufacturer in the world that builds its own AC-drive systems. The result? The new Advanced AC-Drive System is perfectly matched to the EH5000AC-3. It delivers higher torque, faster acceleration, smoother retardation and lower operating costs. With the Hitachi Advanced AC-Drive System, you get...

## THE POWER TO GET MORE DONE.

■ **Auto Cruise Control** keeps vehicle speed constant within the set range by limiting the minimum vehicle speed.

■ **Superior Electric Braking** enables the driver to stop the truck using the electric brake pedal only with the exception of emergencies, because the AC drive control system applies the service brakes automatically just before the stopping, resulting in easy machine operation and longer time between service brake maintenance intervals.

■ **Auto Retarding Control** keeps vehicle downhill speed constant within the set range by limiting the maximum vehicle speed.

■ **IGBT modules** (inverter and chopper) are liquid cooled. Grid resistors, alternator and traction motors are forced-air cooled. The final drive gear oil is circulated, air-cooled and filtered before being directed back to the final drive.

■ **AC-drive wheel motor**  
The Hitachi Dual Path Epicyclic Planetary design provides high efficiency and easy maintenance. Allowing the 1st (outer) planetary carrier to travel at wheel speed provides lower operating temperatures. Better component and lubricant life is the result of an inverter controlled lubricant circulation system that includes lubricant cooling and filtration.



# BUILT TO LAST, BUILT TO PERFORM.

### HANDLES THE BIGGEST, TOUGHEST JOBS.

At mining operations all across the world, Hitachi trucks have earned a reputation for durable and reliable performance. The EH5000AC-3 is adding to that reputation as one of the most durable haulers ever. Rugged and heavy-duty, its redesigned frame is the strongest in its class and can handle your toughest jobs. In addition, the EH5000AC-3 is built with a unique trailing-arm suspension that minimizes frame stress and fatigue, while providing lower tire wear and better steering. This durable system is also the most easy-to-service and maintain. You get access to the strut without removal of the wheel, which reduces your downtime and repair costs. When you choose the EH5000AC-3, you get a hauler that ...

### WORKS LONGER THAN OTHER TRUCKS.

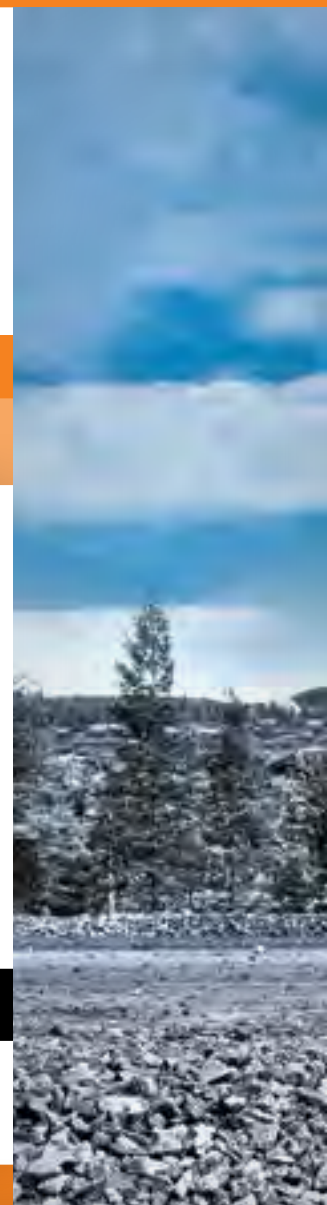

Our new cab structure provides improved safety and durability. The cab frame is stronger and features a three-point isolation-mount design to allow additional independent motion from the truck frame.

The updated body is stiffer and tougher with a six percent steeper floor pitch to reduce spillage and provide solid, well cushioned body-to-frame support. The hoist system is auto-programmed to stop before stroke end to reduce shock.

The redesigned frame also features a bolt-on, high-arch cross member, combined with a new rear axle housing and nose cone design that together deliver higher strength and durability.

The new frame has fully fabricated box-section rails with section height tapered from rear to front. The one-piece top and bottom flanges eliminate cross member tie-in joints. The large radii at frame junctions minimize stress, and all welds are longitudinal to reduce stress cracks and deliver more strength and durability.

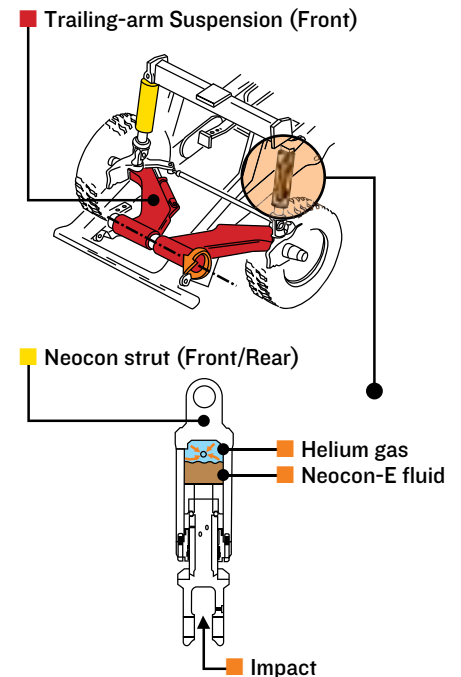



**■ Spindle**

Each spindle is controlled by a hydraulic steering cylinder, which rotates around the king-pin and the outer end of the trailing arm to position the wheels for steering. The spindles are attached by one tie-rod.

**■ King-pin**

Retains the spindle to the trailing arm. Spindle rotates around the king-pin, which is locked in position. The Neocon-E strut attaches to the top.

**■ Trailing Arm**

Main suspension member to which other suspension components are attached. The trailing arms hinge on a torque tube that is clamped to the front of the frame.

**■ Neocon Strut**

The energy absorption and release component of the ACCU-TRAC suspension system. Pinned to ball bushings at the frame and at the top of the king-pin to prevent bending movements from transferring to the strut. Receives only axial input.



**BOTH STRUTS AT NORMAL HEIGHT**

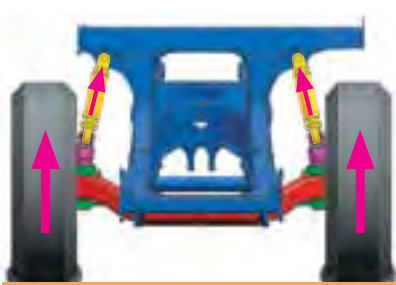

**BOTH STRUTS IN COMPRESSION  
WITH NO HORIZONTAL DEFLECTION**



**DRIVER SIDE STRUT IN COMPRESSION,  
OTHER STRUT IN EXTENSION**

# PRODUCTIVE



Bucket Passes to Dump Trucks											
		Excavator	Bucket Capacity	Passes to Fill							
				1	2	3	4	5	6	7	8
Shovel		EX5600-6	29-m <sup>3</sup> (38.0 cu. yd.) Bucket								
		EX8000-6	40-m <sup>3</sup> (52.3 cu. yd.) Bucket								
Backhoe		EX5600-6	34-m <sup>3</sup> (44.5 cu. yd.) Bucket								
		EX8000-6	43-m <sup>3</sup> (56.2 cu. yd.) Bucket								





# THE TOP-LINE ADDITION THAT IMPROVES YOUR BOTTOM LINE.

## HIGHER UPTIME, HIGHER EARNINGS.

By getting more uptime from your haulers, you get more work done. The end result is improved earnings and a better bottom line. That's exactly what you get with the EH5000AC-3. It's fully designed and engineered to deliver the highest productivity possible in every way – from a cab designed for operator comfort and productivity to exceptionally high load capacities to an advanced monitoring system. Our years of experience building mining trucks gives us the knowledge to build in a series of advanced, functional features that result in more efficient hauling. Put the EH5000AC-3 to work for you and you'll ...

## LOAD UP YOUR PRODUCTIVITY.

■ The EH5000AC-3 is built with an improved payload monitoring system with enhancements to handle rugged loading conditions better. It is fully integrated to the truck's monitoring system (and therefore your Mine Fleet Management System\*) for prompt reporting of tons moved, cycle times, cycle count and distance.

■ The IGBT Advanced AC-Drive System provides faster torque curve for greater acceleration, higher speeds under load and retardation to nearly 0 mph.

■ The improved hydraulic hoist system delivers faster raises and lowers. Hoist raise calibration system can be programmed to cut out the cylinder extension prior to reaching full extension. It also controls the body-lowering speed to ensure maximum cylinder life.

■ High availability results from a strong frame, long-lasting suspension, cooled and lubricated AC-drive system and excellent engine options.

\*Requires optional equipment.

## COMFORT THAT'S MORE PRODUCTIVE.

### THE MOST ADVANCED CAB DESIGN EVER.

At Hitachi, we're also focused on creating cabs that make operators feel more comfortable, which leads to more productivity. The EH5000AC-3 cab gives your operators spacious room, adjustable seating, wide-area visibility, plus a quiet, low vibration interior. This remarkably designed cab helps your operators feel less stressed and less tired, which ultimately makes them more comfortable and capable of handling more work. In addition, your operators will be confident with the unobstructed visibility that adds to safety. When your operators step on board the EH5000AC-3, they'll discover...

### THE PERFECT CAB.

■ Visibility from the cab is enhanced with added mirrors, cameras for blind spots, backup and tire lights and brighter headlamps. Included as standard safety equipment is an analog monitor mounted to the dashboard to display live camera information.

■ The high-efficiency dashboard puts controls within easy reach and good visual contact. A full complement of easy-to-read gauges, a spacious environment, six-way adjustable operator's air seat, tilt/telescopic steering wheel and filtered adjustable air vents contribute to operator comfort.

■ The EH5000AC-3 features a new, easy-access diagonal ladder that provides a safe, quick way to get in and out of the cab.

■ The new wider cab also has a double full-size seat available that provides plenty of space for a trainer to work with an operator.

■ Double wall construction of inner and outer steel panels produces a more structurally sound cab. A three-point rubber isolation-mount design allows greater independent motion from the truck frame, which significantly reduces shocks, vibrations and noise, and keeps operators more comfortable.





■ Heating/cooling capacities have been increased to keep operators comfortable and productive in all types of weather.

■ The new HI-TECH ROPS/FOPS cabs are equipped with a Hitachi controller and a large, centrally mounted color Liquid Crystal Display (LCD) as used in our large size excavators. The display makes operation simple and easy.



## REDUCING SERVICE TIME, RAISING UPTIME.

### SIMPLE, EASY AND CONVENIENT MAINTENANCE.

With some trucks, service and maintenance can be a time-consuming headache – but not with the EH5000AC-3. Designed to keep maintenance simple and uncomplicated, it lets you spend less time working on the truck, and more time working on jobs. Being focused on the mining industry for years, we know and understand all about the biggest challenges in service and maintenance. From this, we've engineered the EH5000AC-3 with the most efficient service and maintenance solutions available. When you want more uptime, choose the EH5000AC-3 and get the hauler that's...

### DESIGNED FOR EASY MAINTENANCE.



■ The AC-drive system has multiple controls that ensure trouble-free reliability and less maintenance. They include grid dry motor control that keeps the grid system dry in cold or wet conditions. A blower control cools the alternator and wheel motors in hot conditions.



■ Hitachi trucks feature a fast-fill system station. This station, located on the left side of the radiator, gives you direct access at ground level for fast filling/topping off of lubricants, grease, hydraulic oil and engine oil. Our auto-lube system provides consistent lubrication to required areas on the truck reducing maintenance downtime. (Couplers are optional.)



■ Four low maintenance air filters with evacuator valves bring easy and safe maintenance.



■ The collapsible step and flat service stage inside the rear axle brings higher serviceability and safety.

# CONVENIENCE



■ The box section design of the frame features one-piece top and bottom flanges that eliminate cross-member tie-in joints and provide a large, exposed center area for quick access to major components.

■ The well laid out design of the water-cooled, high-speed IGBT controls requires less space on the truck. Individual grid resistors provide easier maintenance and improved cooling.

■ Simple sight glasses on the fuel and hydraulic fluid systems allow for a quick pre-shift confirmation that the levels are not below minimums.

■ The trailing-arm suspension allows the front struts to be removed and installed without removing the front brakes or tires. This means fewer tools and less labor time are required, resulting in less downtime and higher productivity.

■ Our service tool allows downloads of a wide variety of information to your technicians' laptops for quicker diagnosis of performance issues.

■ The new system monitor gives you the ability to see information and diagnostics of all onboard systems and controls, helping you reduce downtime with faster and more reliable troubleshooting and analysis.

# SUPPORT



■ Mechanics and service technicians at your Hitachi dealer are highly trained and skilled, and know how to quickly service your equipment and solve any problems. They get you back up to speed quickly and efficiently.

■ To help ensure your trucks stay up and running, we provide parts backup both at our factories and strategic parts depots, so you'll have rapid access to any parts you need.

■ Hitachi factory support managers are assigned to specific mines and provide oversight to help ensure performance.

# FOCUSED ON YOU, NO DISTRACTIONS.

## SUPPORTING YOUR BOTTOM LINE.

It can be frustrating when you need service or parts – especially when you can't get them quickly because the manufacturer is distracted dealing with all kinds of other equipment customers.

At Hitachi, we concentrate on excavators and trucks. So you can count on us to respond rapidly. You'll get the parts you need, the service you want and the customer support you deserve. We stand behind you with a strong dealer network; a skilled factory support team; trained mechanics; and one of the best, most comprehensive warranty and maintenance programs available. Because we're focused on you, you get...

## WHAT YOU NEED, WHEN YOU NEED IT.

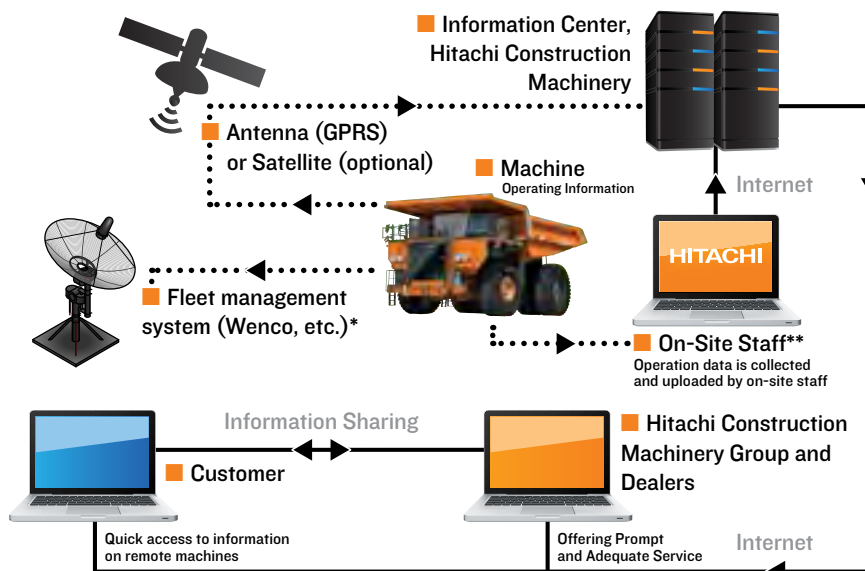

**Remote Machine Management with Global e-Service.**  
This online machine management system allows you to access each on-site machine from a PC in your office. You can get its operating information and location to increase productivity. Operating data and log are sent to a Hitachi server for processing, and then to customer and dealers. This system is available 24/7/365.

Note: In some regions, the Satellite Communication Device is not available by local regulations; the GPRS (mobile) communication device is an option for these regions.

\* DTU (Data Transfer Unit) (optional) is required for connection to fleet management systems.

\*\*WIU (Wireless Interface Unit) transmits operating data via wireless connection for downloading data.

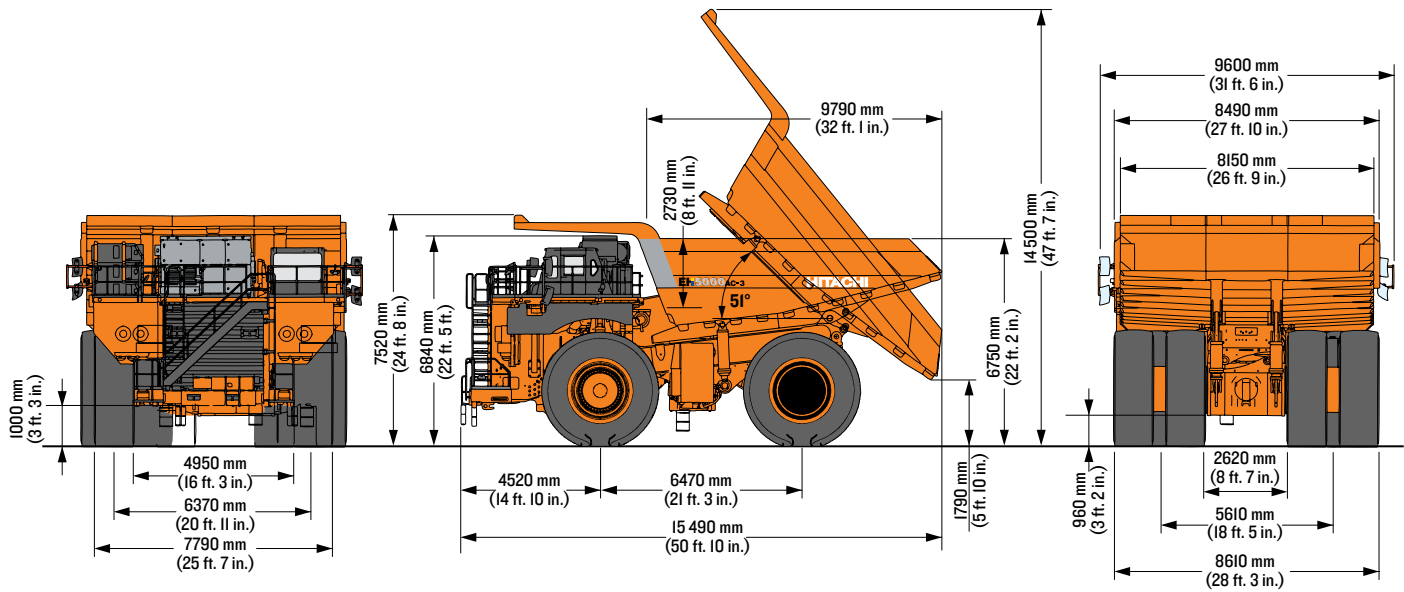

### Engine

	Standard	Optional
Model	Cummins QSKTTA60-CE	MTU 16V4000 C20L
Emission Certification	U.S. E.P.A. Tier-2	Non-Certified
Configuration	4 Cycle Diesel w/ MCR fuel system	4 Cycle Diesel w/ DDEC
Piston Displacement	60 L (3,661 cu. in.)	65 L (3,967 cu. in.)
Rated Output @ 1900 min <sup>-1</sup> (rpm)		
Gross (SAE J1995)	2125 kW (2,850 hp)	2125 kW (2,850 hp)
Net (SAE J1349)	1970 kW (2,640 hp)	1970 kW (2,640 hp)
Maximum Torque (SAE J1995)	10 628 Nm (1084 kgf/m) @ 1,500 min <sup>-1</sup> (rpm)	11 136 Nm (1 136 kgf/m) @ 1,800 min <sup>-1</sup> (rpm)
Aspiration	Turbocharged/Aftercooled	Turbocharged/Aftercooled
Cylinders	16	16
Bore and Stroke	159 mm x 190 mm (6.26 in. x 7.48 in.)	165 mm x 190 mm (6.50 in. x 7.48 in.)
Starting	24-volt electric	24-volt electric

\*Not available in US & Canada. Non-Certified (EPA Emissions) - Fuel optimized version.

### AC-Drive System

#### AC-Control Cabinet

Rectifier	
Number of Units	1
Rated Capacity	1860 kW (2,493 hp)
Inverter	
Number of Units	2
Rated Capacity Per Unit	1200 kVA
Chopper	
Number of Units	2
Rated Capacity Per Unit	1950 kW (2,614 hp)

Equipped with reliable water cooling system. Pressurized cabinet to reduce dust. Equipped with lockable doors for safety. Equipped with small inverters to provide grid motors and blower motors with adequate AC current. Uniquely constructed for the rigid truck application.

#### Alternator

Number of Units	1
Capacity	2050 kVA @ 1,900 min <sup>-1</sup> (rpm)

Equipped with an auxiliary alternator that provides AC current to grid motors, blower motors, control cabinet coolant pump and final drive oil cooling & filtering pump. Air cooled by an AC drive blower.

#### AC-Wheel Motor

Number of units	2
Capacity per unit	920 kW (1,233 hp)
Air cooled by AC-drive blower	

#### Grid Box (Electric Brake)

Number of modules	6
Capacity per unit	625 kW (838 hp) (3 min.)
Equipped with inverter controlled variable speed cooling fan.	

#### Axle

Planetary Ratio	41.0:1
Maximum Speed (Continuous)	56 km/h (34.8 mph)



# SPECS

Tires	
Front and Rear	<b>Rim Width (Standard)</b>
53/80R63	914 mm (36 in)
	<b>Rim Width (Optional)</b>
	965 mm (38 in)

Tire manufacturers offer tires having a range of capabilities suitable for a variety of applications. For high performance hauling it is important to consult with the tire manufacturer to choose a tire that is best matched to truck TGMOW, travel speed and customer specific jobsite conditions. Jobsite condition severity, may result in a reduced truck payload and travel speed recommendation.

Hydraulic System	
Two (2) Hitachi three-stage, double-acting cylinders, with electronic controlled cushioning in retraction and extension, containing dual rod seals and urethane energized scrapers, inverted and outboard mounted. A tandem piston pump combines with four position electronic pilot controlled hoist valve. The electrical controller is mounted to the shift tower.	
Body Raise Travel	58 deg.
Body Raise Time	24 sec.
Body Float Time	22 sec.

Electrical System	
24-volt system. 140 ampere engine driven alternator. Four 245H52, 12 volt, heavy duty batteries connected in series/parallel.	

Steering System	
Closed-center, full time hydrostatic power steering system using two double-acting cylinders and a variable displacement piston pump. Hitachi accumulators provide supplementary steering in accordance with ISO 5010 (SAE J1511), supplying a constant steering rate under all conditions. A tilt/telescopic steering wheel with 35 degrees of tilt and 57 mm telescopic travel is standard.	
Turning Diameter (ISO 7457)	29.9 m (98 ft. 1 in.)

Body Capacities	
Struck (SAE)	148 m <sup>3</sup> (193.6 cu. yd.)
Heap 3:1	185 m <sup>3</sup> (242 cu. yd.)
Heap 2:1 (SAE)	202 m <sup>3</sup> (264.2 cu. yd.)
Body capacity and payload subject to change based on customer specific material density and application.	

Service Capacities	
Crankcase (includes filters): Cummins	260 L (68.7 gal.)
Crankcase (includes filters): MTU	250 L (66.0 gal.)
Engine Cooling System: Cummins	725 L (191.4 gal.)
Engine Cooling System: MTU	667 L (176.2 gal.)
Fuel Tank (Standard)	2900 L (766.1 gal.)
Fuel Tank (Optional)	5100 L (134.2 gal.)
Hydraulic System	950 L (250.8 gal.)
Rear Brake cooling system	170 L (44.7 gal.)
Planetary Drives (L&R)	360 L (95.1 gal.)
Front Wheels (L&R)	24 L (6.3 gal.)
Control Cabinet cooling system	59 L (15.5 gal.)
Main Accumulator	2 x 70 L (2 x 18.4 gal.)
Windshield Washer	20 L (5.2 gal.)

Weights (Approximate)	
Net machine weight stated below includes standard equipment. Net machine weight changes will directly affect the Nominal Payload.	
	<b>53/80R63</b>
Chassis with Hoist	174 000 kg (383,604 lb.)
Body	30 000 kg (66,139 lb.)
Net Machine Weight	204 000 kg (449,743 lb.)

Net Machine Weight, includes operator and 100% fuel.	
Note: Body parts mean assembled standard parts to the body, such as mud guards, body pads, rock ejector bars, arm guard and fasteners.	
Nominal Payload	296 tonnes (326 tons)
Target GMOW	500 000 kg (1,102,311 lb.)

Note: The Nominal Payload specification is calculated using the Hitachi Loading Policy. Specific job site requirements may result in an adjustment to the Nominal Payload weight. Consult your Hitachi dealer for a truck configuration which will match your haulage application.

Weight Distribution	Front	Rear
Empty	48%	52%
Loaded	33%	67%

### Brake System

Brake system complies with ISO 3450 (SAE J1473).

#### Service Brake

Service braking for the EH5000AC-3 is made up of front and rear hydraulically applied brakes and the electric brake.

##### Front Axle – Dry Disc

Disc Diameter Each (2 discs/axle, 4 calipers/disc) 133.3 cm (4 ft. 4 in.)

##### Rear Axle – Oil-cooled Wet Disc

Total Friction Area per Brake 75 760 cm<sup>2</sup> (81 sq. ft.)

#### Secondary

Two of front hydraulic, rear hydraulic and electric brake within the service brake system provide modulated reserve braking capability. Both front and rear hydraulic brakes are automatically applied when loss of pressure is detected.

#### Parking Brake

This system is designed to use spring applied, hydraulically released brake calipers to hold the truck stationary.

#### Electric Brake

The Electric Brake is used for usual operating brake for the EH5000AC-3. The Hitachi AC Drive system provides all necessary truck speed control, including speed reduction to 0 km/h travel speed when the electric brake pedal is depressed. Also, the rear service brakes automatically apply at speeds below 0.5 km/h if this pedal is depressed.

Maximum dynamic braking (Standard)

3750 kW (5027 hp)

#### Load/Dump Brake Apply

Through activation of a switch by the operator, a solenoid is energized, sending full brake pressure to apply the rear Wet Disc brakes. For use during the load and dump cycles.

### Hi-Tech ROPS/FOPS Cab

ROPS complies with ISO3471 and SAE J1040-May 94, FOPS complies with ISO3449. A three-point rubber ISO-mount arrangement to the high-arch cross member minimizes vibration transfer to the operator compartment. New wider cab with double full size seat available and enough trainer's leg space brings comfortable operating and training.

#### Monitoring System

A new Hitachi system monitor provides display information and diagnostics of all onboard systems and controls which include the engine and Hitachi AC drive. Data links offer complete integration, while a color Liquid Crystal Display (LCD) clearly details machine functions. Downtime is minimized with faster and more reliable troubleshooting and analysis. A new Hitachi load monitoring system offers benefits such as better equipment utilization on the jobsite, accurate unit and fleet production results, and benchmark unit statistics against fleet results. Cycle time, distance and cycle count can all be measured and recorded as information that can help in developing higher productivity. The Hitachi load monitoring system is fully integrated with the Hitachi vehicle monitoring system and display interface, avoiding potential failure or error common in aftermarket systems.



- |   |   |
|---|---|
| <ol style="list-style-type: none"> <li>1. Model</li> <li>2. Drive related warning indicators</li> <li>3. Turn signal indicator</li> <li>4. Engine stop warning indicator</li> <li>5. Central warning indicator</li> <li>6. Tachometer</li> <li>7. Shift lever position indicator</li> <li>8. Hour meter</li> <li>9. Hydraulic related warning indicators</li> <li>10. Light indicators</li> <li>11. Fuel gauge</li> <li>12. Load meter</li> <li>13. Clock</li> <li>14. Wheel motor temperature gauge</li> </ol> | <ol style="list-style-type: none"> <li>15. Coolant temperature gauge</li> <li>16. Engine oil pressure gauge</li> <li>17. Indicate message</li> <li>18. Indicate SAE code</li> <li>19. Indicate HCM code</li> <li>20. Brake /steering hydraulic oil pressure gauge</li> <li>21. Speedometer (with odometer)</li> <li>22. Engine related warning indicators</li> <li>23. Stop valve warning indicator</li> <li>24. AC drive system maintenance required warning indicator</li> <li>25. Body angel indicator</li> <li>26. Drive control status indicator</li> <li>27. Ambient temperature</li> </ol> |
|---|---|

### Camera Monitoring System

Included as standard safety support equipment, an analog monitor has been mounted to the dashboard to display live camera information of the rear and right front area.

### Suspension

#### Front Suspension

Independent trailing arms make up the front axle. NEOCON struts containing energy-absorbing gas and compressible NEOCON-E™ fluid are mounted between the trailing arms and frame. Inherent in the NEOCON strut design is a variable damping and rebound feature.

#### Rear Suspension

"A" frame structure, integral with axle housing, links the drive axle to the frame at forward center point with pin and spherical bushing. A track rod provides lateral stability between the frame and drive axle. Heavy-duty rear-mounted NEOCON struts containing energy-absorbing gas and compressible NEOCON-E™ fluid suspend the drive axle from the frame. Integral variable damping and rebound feature included.

# SPECS

## Body

An extended canopy protects service deck area. High tensile strength 400 BHN abrasion resistant alloy steel is used in thicknesses indicated below:

Floor	16 mm (0.6 in.)
Front	9 mm (0.35 in.)
Sides	9 mm (0.35 in.)
Canopy	6 mm (0.2 in.)
Corners	12 mm (0.47 in.)

High strength 690 N/mm<sup>2</sup> (100 000 psi) alloy steel is also used for the canopy side members and floor stiffeners. The body is rubber cushioned on the frame.

### Optional Body Liners

Floor & Corners	12 mm (0.47 in.)
Sides & Front	6 mm (0.2 in.)
Canopy	6 mm (0.2 in.)

Special plate thicknesses and partial plates are available.



## Hitachi Bodies

### Tough Body Structure

Designed by Hitachi for long lasting strength and productivity. Hitachi offers customized solutions to match specific load and haul applications. Optional bodies and parts are engineered on request.

### Standard Body

The Hitachi standard body is designed to accommodate the needs of popular mid-range material densities and the most popular loading machines. Various options, such as liners, spill guard, extended canopy are available.

### Coal Body (Optional)

The Hitachi coal body has been designed for low material density, small fragmented, low abrasive material. This coal body offers excellent material shedding, low empty weight and large capacity.

### Iron Ore Body (Optional)

The Hitachi iron ore body has been designed for use in rugged iron ore mining applications. The body has been designed for high density material and optimized loading and dumping.

### Customized Body (Optional)

Upon request and approval, Hitachi will design bodies to suit special mining applications.

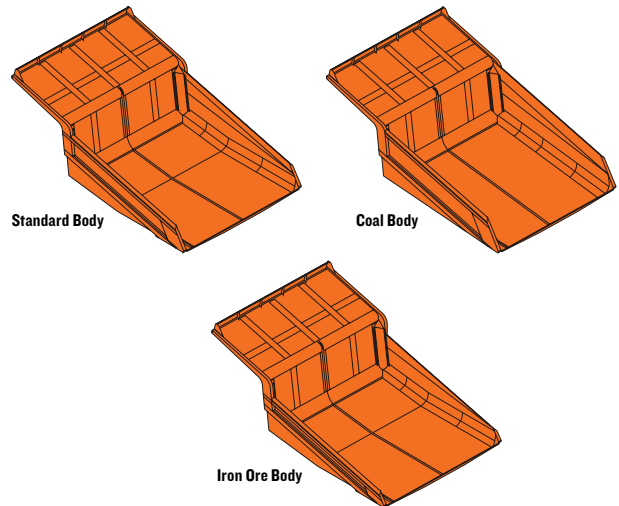

## Frame

Full fabricated box section main rails with section height tapered from rear to front. Narrow at the rear to support the load and wider at the front allowing truck stability and excellent engine access for servicing. One-piece top and bottom flanges that eliminate cross member tie-in joints and provide a large exposed center area for access to major components. Large radii at frame junctions are blended and ground to minimize stress concentrations. Weld joints are oriented longitudinally to the principal flow of stress for greater durability and more strength. The new "bolt-on" High Arch Design requires less assembling time and no welding. The design provides higher structural quality and better serviceability during engine overhaul.

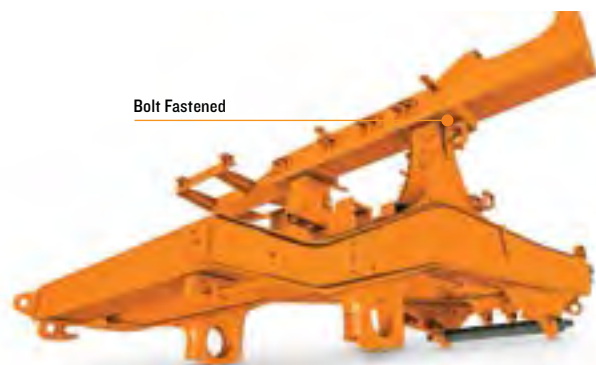

### Hitachi Loading Policy

#### Operational Benefits

#### Haulroad Safety

Truck loading within the limitations of the Hitachi Loading Policy will result in designed and certified operational performance of the steering, brake and ROPS systems of the truck.\*

#### Efficient Productivity

Truck loading within the limitations of the Hitachi Loading Policy will result in optimizing the fuel economy and travel speed performance to which the truck was designed to.\*

#### Availability and Maintenance

Lower maintenance costs and higher availability can be achieved if truck loading is within the limitations of the Hitachi Loading Policy.\*

\*Hitachi recommended maintenance is required.

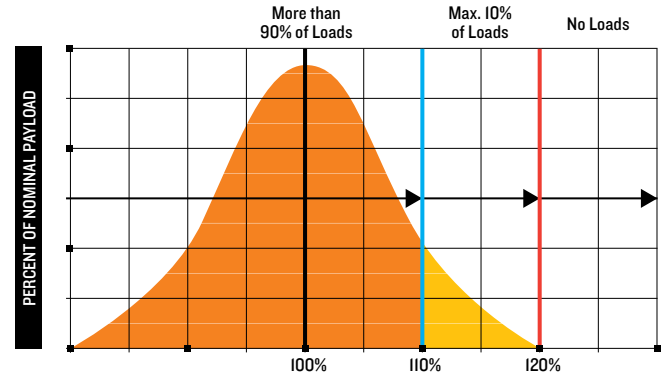

1: More than 90% of all loads must fall below 110% area (Orange area).

2: If necessary due to excessive variation in material density, loader bucket fill-factors or bucket sizes, loading the truck to between 110% and 120% of Nominal Payload is allowed if it accounts for less than 10% of all loads (Yellow area).

3: Loading above 120% of Nominal Payload is not allowed. (Red Area)

### Perimeter Visibility (Standard)

The addition of mirrors and cameras to the base model make the truck compliant to the perimeter viewing requirement of standards ISO 5006 and ISO 14401.

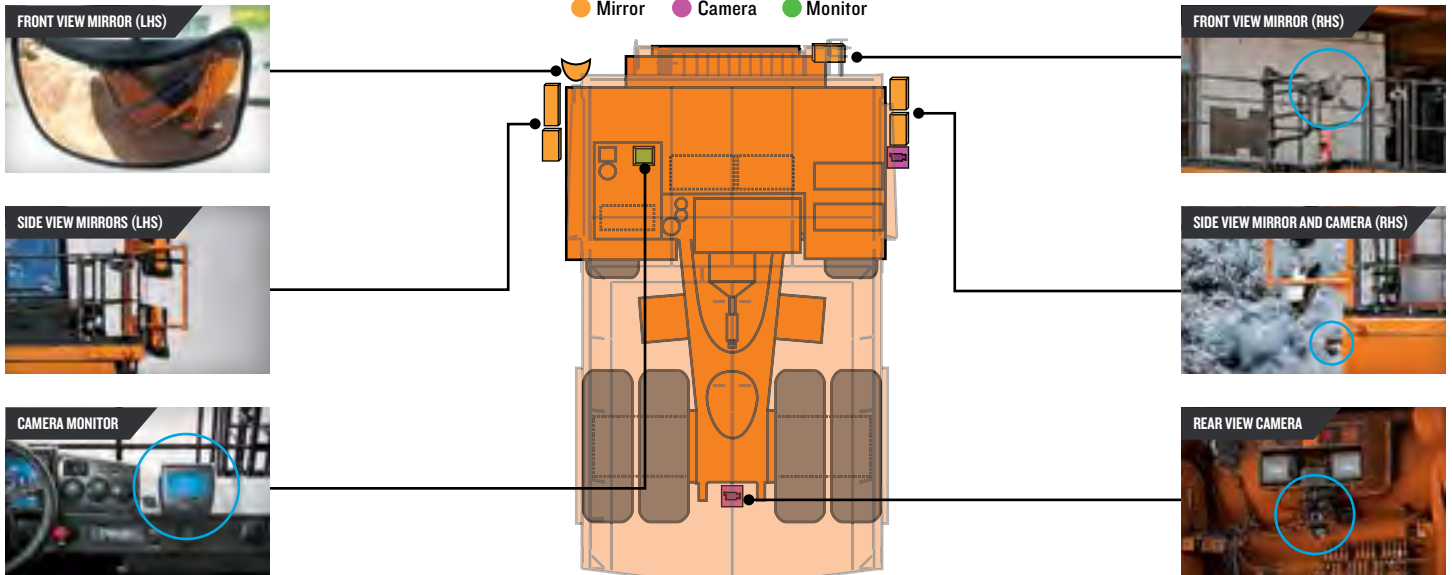

# SPECS

## SkyAngle™

### Skyangle (Peripheral vision support system)

The SkyAngle feature is available to significantly increase peripheral vision around the dump truck by providing synthesized multiple images captured by cameras specifically positioned at four locations around the truck. The feature displays camera views on a single monitor to allow operators an auxiliary means of checking for ground level obstacles.

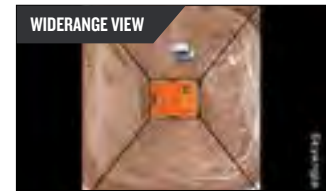

Available on neutral or forward only

# ADDITIONAL EQUIPMENT

Key: ● Standard ▲ Optional or special kit

General
● AC drive system
● Auto cruise control
● Auto retarding control
● Automatic lubrication system (Lincoln)
● Battery isolation switch
● Body prop cable
● Control cabinet pressurized/liquid cooled/ lockable
● Deck mounted muffler
● Deck mounted stone guards
● Diagonal front stairway
● Electric controlled hoist system
● Electric horns (4)
● Emergency ladders (2)
● Engine access ladders (2)
● Engine shutdown switch
● Beside engine (2)
● Ground level, on bumper (1)
● Inside rear axle (1)
● Fan and belt guards
● Fan clutch
● Fast fluid filling system
● Fast fuel filling system provision
● Final drive lubricant cooling
● Final drive lubricant filtration
● Front view mirror, LHS/RHS
● Fuel/Water separator
● Fuel tank, 2900 L (766 gal.)
● Ground level battery box
● Ground level relay box
● IGBT controlled blower fan motors (2)
● IGBT controlled final drive lubricant motor (1)
● IGBT controlled grid fan motors (6)
● Load weighing system
● NEOCON suspension struts
● Rear view camera
● Rear view mirrors (4)
● Rims, 0.91 m (36 in.)
● Side view camera (RHS)
● Suction port shut off valve at hydraulic tank
● Supplementary front braking system, accumulators
● Supplementary rear braking system, accumulators
● Supplementary steering system, accumulators
● Tow hooks, front
● Tow lugs, rear

Cab
● Air conditioner
● AM-FM radio
● Auxiliary outlet, 12 volt
● Camera monitor
● Engine shutdown switch
● Heater and defroster
● Integral ROPS/FOPS cab
● LCD system monitor
● Load and dump brake switch
● Override switch
● Communication system (alternative)*
● Satellite data transmitting system
● Seat with 2-point, 50 mm (1.97 in.) width seat belt
● Full size operator's seat, air suspension & 6 position
● Regular size trainer's seat, mechanical & adjustable
● Tinted safety glass, with roll-down windows
● WIU (Wireless Interface Unit) *
● 12-volt accessory connection
Monitor Panel
● AC drive system maintenance required warning indicator
● Ambient temperature
● Body angel indicator
● Brake/steering hydraulic oil pressure gauge
● Central warning indicator
● Clock
● Coolant temperature gauge
● Drive control status indicator
● Drive related warning indicators
● Engine oil pressure gauge
● Engine related warning indicators
● Engine stop warning indicator
● Fuel gauge
● Hour meter
● Hydraulic related warning indicators
● Indicate HCM code
● Indicate message
● Indicate SAE code
● Light indicators
● Load meter
● Model
● Shift lever position indicator
● SkyAngle (peripheral vision support system)
● Speedometer (with odometer)
● Stop valve warning indicator
● Tachometer
● Turn signal indicator
● Wheel motor temperature gauge

Machine Lights	
● Backup lights (2)	
● Clearance lights (4)	
● Combination stop and tail lights (2)	
● Deck lights (2)	
● Diagonal front stairway light	
● Engine compartment lights (2)	
● HID headlights (8)	
● Payload external indicators, 2 locations of 2 lights each	
● Rear axle compartment light	
Optional Equipment	
▲ Auxiliary dump connection	
▲ Auxiliary steer connection	
▲ Body liners (400BHN)	
▲ Body prop pins	
▲ Body sizes **	
▲ Cold weather package **	
▲ Communication system (alternative)*	
● GPRS communication system	
▲ Fast fluid filling system couplers	
▲ Fast fuel filling system coupler	
▲ Fuel tank, 5100 L (1,347 gal.)	
▲ Full size operator's seat, air suspension & 6 position, with 3-point, 50 mm width seat belt	
▲ Full size trainer's seat, air suspension & 6 position, with 2-point, 50 mm (1.97 in.) width seat belt	
▲ Halogen front tire lights (2)	
▲ Heated mirrors	
▲ Loadweight displays (2)	
▲ Rims, 0.97 m (38 in.)	
▲ Sound attenuation package **	
▲ Spare rim	
▲ Tire guards (2)	
▲ Trolley assist configuration **	
Optional Equipment Weight	
▲ Body liners (400BHN) plates including floor & corners (12 mm [0.47 in] thicknesses), sides & front and canopy drop edge (6 mm [0.24 in] thicknesses)	9300 kg (20,502 lb.)
▲ 5100 L (1,347 gal.) fuel tank with 100 % fuel (additional weight to the standard tank with 100 % fuel)	2200 kg (4850 lb.)
▲ Body prop pins	80 kg (176 lb.)
▲ Loadweight displays (2)	150 kg (331 lb.)
▲ Rims, 38 in. (additional)	780 kg (1,720 lb.)

See your Hitachi dealer for further information.

\*The availability of the system depends on licensing regulations in each country. Please contact Hitachi dealer for more information. \*\*Engineered on request. Note: Regarding the Cummins engine, fuel optimized ratings available to meet worldwide emissions and enhanced fuel efficiency. Contact your nearest authorized Cummins Distributor for details and availability.

# SHIPPING

## Shipping

	Skid/Case	Description	Net Weight	Gross Weight	Length	Width	Height	Volume
1	Steelskid	Frame	54 200 kg (119,491 lbs.)	54 380 kg (119,887 lbs.)	12 460 mm (40 ft. 11 in.)	4550 mm (14 ft. 11 in.)	3850 mm (12 ft. 8 in.)	218.27 m <sup>3</sup> (285.49 cu. yd.)
2	Steelskid	Axle; Front	18 200 kg (40,124 lbs.)	19 100 kg (42,108 lbs.)	7700 mm (25 ft. 3 in.)	3000 mm (9 ft. 10 in.)	1780 mm (5 ft. 10 in.)	41.12 m <sup>3</sup> (53.78 cu. yd.)
3	Steelskid	Cab	2512 kg (5,538 lbs.)	2662 kg (5,869 lbs.)	2900 mm (9 ft. 6 in.)	2050 mm (6 ft. 9 in.)	2460 mm (8 ft. 1 in.)	14.63 m <sup>3</sup> (19.14 cu. yd.)
4	Steelskid	Support; Cab	3000 kg (6,614 lbs.)	3078 kg (6,786 lbs.)	7250 mm (23 ft. 9 in.)	2600 mm (8 ft. 6 in.)	1150 mm (3 ft. 9 in.)	21.68 m <sup>3</sup> (28.36 cu. yd.)
5	Steelskid	Fender (L) & (R)	811 kg (1,788 lbs.)	897 kg (1,978 lbs.)	2550 mm (8 ft. 4 in.)	2360 mm (7 ft. 9 in.)	2130 mm (7 ft.)	12.82 m <sup>3</sup> (16.77 cu. yd.)
6	Steelskid	Bumper (R)	139 kg (306 lbs.)	163 kg (359 lbs.)	1030 mm (3 ft. 5 in.)	870 mm (34 in.)	1570 mm (5 ft. 2 in.)	1.41 m <sup>3</sup> (1.84 cu. yd.)
7	Steelskid	Deck (R1)	389 kg (858 lbs.)	460 kg (1,014 lbs.)	2380 mm (7 ft. 10 in.)	2150 mm (7 ft. 1 in.)	1350 mm (4 ft. 5 in.)	6.91 m <sup>3</sup> (9.04 cu. yd.)
8	Steelskid	Deck (R2)	2975 kg (6,559 lbs.)	3088 kg (6,808 lbs.)	2320 mm (7 ft. 7 in.)	2200mm (7 ft. 3 in.)	2300 mm (7ft. 7 in.)	11.74 m <sup>3</sup> (15.36 cu. yd.)
9	Skid	Support	353 kg (778 lbs.)	470 kg (1,036 lbs.)	2540 mm (8 ft. 4 in.)	1730 mm (5 ft. 8 in.)	570 mm (22 in.)	2.51 m <sup>3</sup> (3.28 cu. yd.)
10	Case	Control; Cabinet	2414 kg (5,322 lbs.)	4070 kg (8,973 lbs.)	3620 mm (11 ft. 11 in.)	1820 mm (6 ft.)	2450 mm (8 ft.)	16.14 m <sup>3</sup> (21.11 cu. yd.)
11	Steelskid	Deck and Handrails	654 kg (1,442 lbs.)	860 kg (1,896 lbs.)	4500 mm (14 ft. 9 in.)	1900 mm (6 ft. 3 in.)	1530 mm (5 ft.)	13.08 m <sup>3</sup> (17.11 cu. yd.)
12	Steelskid	Misc. Parts	443 kg (977 lbs.)	545 kg (1,202 lbs.)	5100 mm (16 ft. 9 in.)	950 mm (3 ft. 1 in.)	1480 mm (4 ft. 10 in.)	7.17 m <sup>3</sup> (9.38 cu. yd.)
13	Steelcase	Misc. Parts	1429 kg (3,150 lbs.)	1539 kg (3,393 lbs.)	2260 mm (7 ft. 5 in.)	1150 mm (3 ft. 9 in.)	1110 mm (3 ft. 8 in.)	2.89 m <sup>3</sup> (3.78 cu. yd.)
14	Steelcase	Misc. Parts	731 kg (1,612 lbs.)	771 kg (1,700 lbs.)	1150 mm (3 ft. 9 in.)	1130 mm (3 ft. 8 in.)	550 mm (22 in.)	0.72 m <sup>3</sup> (0.94 cu. yd.)
15	Steelcase	Misc. Parts	648 kg (1,429 lbs.)	738 kg (1,627 lbs.)	2260 mm (7 ft. 5 in.)	1150 mm (3 ft. 9 in.)	740 mm (29 in.)	1.92 m <sup>3</sup> (2.51 cu. yd.)
16	Steelskid	Tank; Fuel	1622 kg (3,576 lbs.)	1683 kg (3,710 lbs.)	2150 mm (7 ft. 1 in.)	1650 mm (5 ft. 5 in.)	2670 mm (8 ft. 9 in.)	9.47 m <sup>3</sup> (12.39 cu. yd.)
17	Steelskid	Front; Suspension	1240 kg (2,734 lbs.)	1285 kg (2,833 lbs.)	2500 mm (8 ft. 2 in.)	970 mm (3 ft. 2 in.)	550 mm (22 in.)	1.33 m <sup>3</sup> (1.74 cu. yd.)
18	Steelskid	Accumulator (I)	650 kg (1,433 lbs.)	684 kg (1,508 lbs.)	2520 mm (8 ft. 3 in.)	1010 mm (3 ft. 4 in.)	450 mm (18 in.)	1.15 m <sup>3</sup> (1.50 cu. yd.)
19	Steelcase	Misc. Parts	354 kg (780 lbs.)	444 kg (979 lbs.)	2260 mm (7 ft. 5 in.)	1150 mm (3 ft. 9 in.)	740 mm (29 in.)	1.92 m <sup>3</sup> (2.51 cu. yd.)
20	Steelcase	Piping; Intake	156 kg (344 lbs.)	246 kg (542 lbs.)	2260 mm (7 ft. 5 in.)	1150 mm (3 ft. 9 in.)	740 mm (29 in.)	1.92 m <sup>3</sup> (2.51 cu. yd.)
21	Steelskid	Muffler	328 kg (723 lbs.)	373 kg (822 lbs.)	2790 mm (9 ft. 2 in.)	1400 mm (4 ft. 7 in.)	730 mm (29 in.)	2.85 m <sup>3</sup> (3.73 cu. yd.)
22	Steelskid	Spacer	403 kg (888 lbs.)	440 kg (970 lbs.)	1500 mm (4 ft. 11 in.)	1500 mm (4 ft. 11 in.)	1100 mm (3 ft. 7 in.)	2.48 m <sup>3</sup> (3.24 cu. yd.)
23	Skid	Plenum Chamber	96 kg (212 lbs.)	145 kg (320 lbs.)	2600 mm (8 ft. 6 in.)	700 mm (2 ft. 4 in.)	850 mm (33 in.)	1.55 m <sup>3</sup> (2.03 cu. yd.)
24	Steelskid	Travel; Device	16 510 kg (36,398 lbs.)	17 081 kg (37,657 lbs.)	3600 mm (11 ft. 10 in.)	1750 mm (5 ft. 9 in.)	2100 mm (6 ft. 11 in.)	13.23 m <sup>3</sup> (17.30 cu. yd.)
25	Steelskid	Travel; Device	16 510 kg (36,398 lbs.)	17 081 kg (37,657 lbs.)	3600 mm (11 ft. 10 in.)	1750 mm (5 ft. 9 in.)	2100 mm (6 ft. 11 in.)	13.23 m <sup>3</sup> (17.30 cu. yd.)
26	Steelskid	Rim	2740 kg (6,041 lbs.)	2850 kg (6,283 lbs.)	1900 mm (6 ft. 3 in.)	1900 mm (6 ft. 3 in.)	1500 mm (4 ft. 11 in.)	5.42 m <sup>3</sup> (7.09 cu. yd.)
27	Steelskid	Rim	2740 kg (6,041 lbs.)	2850 kg (6,283 lbs.)	1900 mm (6 ft. 3 in.)	1900 mm (6 ft. 3 in.)	1500 mm (4 ft. 11 in.)	5.42 m <sup>3</sup> (7.09 cu. yd.)
28	Steelskid	Rim	2740 kg (6,041 lbs.)	2850 kg (6,283 lbs.)	1900 mm (6 ft. 3 in.)	1900 mm (6 ft. 3 in.)	1500 mm (4 ft. 11 in.)	5.42 m <sup>3</sup> (7.09 cu. yd.)
29	Steelskid	Rim	2740 kg (6,041 lbs.)	2850 kg (6,283 lbs.)	1900 mm (6 ft. 3 in.)	1900 mm (6 ft. 3 in.)	1500 mm (4 ft. 11 in.)	5.42 m <sup>3</sup> (7.09 cu. yd.)
30	Steelskid	Rim	2980 kg (6,570 lbs.)	3090 kg (6,812 lbs.)	1900 mm (6 ft. 3 in.)	1900 mm (6 ft. 3 in.)	1600 mm (5 ft. 3 in.)	5.78 m <sup>3</sup> (7.56 cu. yd.)
31	Steelskid	Rim	2980 kg (6,570 lbs.)	3090 kg (6,812 lbs.)	1900 mm (6 ft. 3 in.)	1900 mm (6 ft. 3 in.)	1600 mm (5 ft. 3 in.)	5.78 m <sup>3</sup> (7.56 cu. yd.)
Body - 2 Piece								
	Steelskid	Body (L)	9770 kg (21,539 lbs.)	9770 kg (21,539 lbs.)	13 908 mm (45 ft. 8 in.)	3145 mm (10 ft. 4 in.)	3550 mm (15 ft. 4 in.)	155.28 m <sup>3</sup> (203.10 cu. yd.)
	Steelskid	Body (R)	19 500 kg (42,990 lbs.)	19 500 kg (42,990 lbs.)	13 908 mm (45 ft. 8 in.)	5585 mm (18 ft. 4 in.)	4025 mm (13 ft. 2 in.)	312.65 m <sup>3</sup> (408.93 cu. yd.)
Body - 3 Piece								
	Steelskid	Body (L)	9770 kg (21,539 lbs.)	9770 kg (21,539 lbs.)	13 908 mm (45 ft. 8 in.)	3145 mm (10 ft. 4 in.)	3550 mm (15 ft. 4 in.)	155.28 m <sup>3</sup> (203.10 cu. yd.)
	Steelskid	Body (C)	9530 kg (21,010 lbs.)	9530 kg (21,010 lbs.)	13 908 mm (45 ft. 8 in.)	2654 mm (8 ft. 8 in.)	3685 mm (15 ft. 4 in.)	136.02 m <sup>3</sup> (177.91 cu. yd.)
	Steelskid	Body (R)	9830 kg (21,671 lbs.)	9830 kg (21,671 lbs.)	13 908 mm (45 ft. 8 in.)	3145 mm (10 ft. 4 in.)	3550 mm (15 ft. 4 in.)	155.28 m <sup>3</sup> (203.10 cu. yd.)

# HITACHI

[hitachiconstruction.com](http://hitachiconstruction.com)